



CP Hire 

**INTERACTIVE
PLANT CATALOGUE
2022/23**

01 |

CONTENTS

OUR VALUES >	02
ABOUT CP HIRE >	03
CP SAFE >	04
CUSTOMER SUPPORT >	05
CUSTOMER SERVICE >	06
EXTENSIVE FLEET >	07
EXCAVATORS >	08
DUMPERS >	09
DUMP TRUCKS >	10
COMPACTION >	11
TELEHANDLERS >	12
BOWSERS >	13
TRAILER AND WELFARE UNITS >	14
PORTABLE COMPRESSED AIR >	15
HYDRAULIC BREAKERS >	16
ACCREDITATION AND AWARDS >	17
COMMUNITY WORK >	18
OPERATED PLANT HIRE >	19
OPENING AN ACCOUNT >	20



02 |

EQUIPMENT HIRE ACROSS WALES & ENGLAND

OUR MISSION

To give our customers the best possible hire experience.

WE ARE COMMITTED TO GROWTH

- Welcome the future
- Operate with focus and urgency
- Be flexible, enthusiastic and ready
- Keep a positive outlook and help others

OUR CUSTOMERS COME FIRST

- Listen to and understand our customers' needs
- Anticipate and exceed expectations
- Do the right thing, first time, every time
- Use our initiative to make a difference
- Monitor quality in everything we do



03 |

THE RIGHT WAY, FIRST TIME, EVERY TIME

Having a reputation for excellent customer service doesn't come easily. We continually invest in people and practices to ensure our customers get the very best. For over 50 years, CP Hire has been delivering first-class construction equipment products to construction sites all over the UK. We do this safe in the knowledge that all our equipment is tested and certified to the very highest standards.

From very humble beginnings CP Hire has positioned itself as a company large enough to cater for nationwide contractors but has never lost its focus

for local customers. We go through a continuous investment programme, which has resulted in over £55 million of equipment being introduced into the wider fleet over the last 5 years.

Knowledge is power - throughout CP Hire you'll find industry-experienced staff that take pride in giving you the best possible advice. When you're not sure of the right piece of equipment for your site, our in-depth knowledge of machines and applications gives us the edge when selecting the right equipment for your job.

[Find out more >](#)

OVER
6000
ITEMS OF PLANT



2 YEARS
AVERAGE
AGE PROFILE

SIXTY
NATIONWIDE
**SERVICE
ENGINEERS**



**RAIL &
TRACKSIDE
APPROVED**



Jonathan Davies
Business Manager

OUR CP SAFE CULTURE

Comprised of four fundamental pillars, CP Safe is our initiative centred around how we operate and dedicates itself to the following remits: Health and Safety, Training, Behaviours and Quality

Being renowned for our excellent service is nothing without the highest levels of safety our customers and staff have come to expect. CP Safe facilitates this by prioritising safety in every working environment, under any circumstance.

As a backbone of CP Hire, CP Safe invests the essential time to provide qualifications, such as IOSH, and skills for all our staff whilst adopting safer practices and empowering customers alike. We firmly believe developing staff ensures a brighter future for all by bringing safety to the forefront.

Whilst committing to paramount health and safety practices, our expectation of quality never falters. CP Hire thrives on exceeding expectations and continues to do so under a strong foundation of health and safety to always meet the standards of our customers.

CP Hire - is what we do
CP Safe - is how we do it



Nigel Hutchings
Health & Safety Manager



05 |

SUPERIOR CUSTOMER AND CALL-OUT SUPPORT

 **2HR**
CALL-OUT
TIME

Our fully-trained equipment engineers provide on-site expertise with the support of a head office service team that deals directly with the customer. Utilising the very latest service software enables us to report instantly on diagnosing and solving any faults or breakdowns.

86%  **1ST**
TIME
FIX RATE

Reacting quickly to equipment issues is paramount. Our engineers use tablet-based software that gives them direct access to all our partner suppliers. Experienced service personnel are always available at our national service desk to answer any query.

 **FULLY**
CP Safe 
TRAINED

Any necessary services or certification are planned well ahead of time, giving you peace of mind and minimising disruption. Our on-going aim is to ensure the smooth running of your site and that our equipment is always 'safe to work'.

Phone: 0845 505 70 70 (Option 1)
Email: service@cphire.com



06 |

EXPERIENCED AND RELIABLE CUSTOMER SERVICE

All of our staff are on-hand to help you, our customer. We appreciate your business and work hard to ensure you are totally satisfied with our products and their support.

As a company we have a huge amount of experience within our depot network, not just supporting the product on your site, but also at the end of a phone to answer any query you may have about specifications, attachments or transportation.

If you can't find what you're looking for, then please ask at one of our depots. We are only too happy to source the right product for your site.

[Visit our contact page to get in touch >](#)

OUR LATEST COMPREHENSIVE FLEET

[VIEW ONLINE](#)

We continually commit reinvesting to and updating our fleet year upon year. We use premium brand suppliers that are recognised the world over, placing our faith in their reliability so we can supply our customers with complete confidence.

Our equipment yields an average age profile of 2 years that uses the latest software technology to create reports built around our customers' requirements. Whether it be fuel economy or hours worked to location or instant fault reports - we can check in an instant.



08 |

EXCAVATORS

VISIT WEBPAGE



EXCAVATOR

0.8 TONNE MICRO EXCAVATOR



The compact design of this machine and its short tail swing radius mean that this excavator can work in the narrowest of areas.

HARD HAT REQUIRED SEATBELT BEACON SECURITY FOB*

MAX DIGGING DEPTH	1720 MM
WIDTH	700-860 MM
HEIGHT	2260 MM
FUEL TANK CAP	12 LTRS
ENGINE SIZE	7.6 KW
WEIGHT	900 KG



EXCAVATOR

1.6 TONNE CANOPIED EXCAVATOR



These easily transported machines are ideal for landscaping and confined building sites. They work well with the narrow access dumper.

HARD HAT REQUIRED SEATBELT BEACON SECURITY FOB*

MAX DIGGING DEPTH	2160 MM
WIDTH	980 MM
HEIGHT	2280 MM
FUEL TANK CAP	24.5 LTRS
ENGINE SIZE	12.5 KW
WEIGHT	1590 KG



EXCAVATOR

1.9 TONNE EXCAVATOR



The 1.9 tonne mini excavator range delivers high levels of productivity, excellent fuel efficiency and durability on a variety of construction projects. Spacious and comfortable, the excavator offers enhanced visibility and user-friendly features including expandable crawler tracks and a short-tail swing radius.

HARD HAT REQUIRED SEATBELT BEACON SECURITY FOB*

MAX DIGGING DEPTH	2390 MM
WIDTH	990 MM
HEIGHT	2380 MM
FUEL TANK CAP	20 LTRS
ENGINE SIZE	11.5 KW
WEIGHT	1880 KG



EXCAVATOR 3 TONNE EXCAVATOR



For all landscaping work and trench digging, this excavator will provide invaluable help.



MAX DIGGING DEPTH	2735 MM
WIDTH	1550 MM
HEIGHT	2435 MM
FUEL TANK CAP	38.5 LTRS
ENGINE SIZE	18.1 KW
WEIGHT	2665 KG



EXCAVATOR 5 TONNE EXCAVATOR



The 5 tonne mini excavator provides more power, with greater digging precision and extended reach.



MAX DIGGING DEPTH	3470 MM
WIDTH	1980 MM
HEIGHT	2550 MM
FUEL TANK CAP	63 LTRS
ENGINE SIZE	34.1 KW
WEIGHT	5415 KG



EXCAVATOR 6 TONNE EXCAVATOR



The 6 tonne mini excavator provides slightly more reach than the 5 tonne, but with similar dimensions for accessibility.



MAX DIGGING DEPTH	4050 MM
WIDTH	1920 MM
HEIGHT	2563 MM
FUEL TANK CAP	110 LTRS
ENGINE SIZE	36.2 KW
WEIGHT	5700 KG



EXCAVATOR 8 TONNE EXCAVATOR



This mid-range excavator allows you to put power and precision where you need it. The spacious cab has excellent visibility. This digger is available with zero tail swing so it can work in narrow areas reducing the likelihood of accidents.



MAX DIGGING DEPTH	4108 MM
WIDTH	2300 MM
HEIGHT	2541 MM
FUEL TANK CAP	147 LTRS
ENGINE SIZE	55.4 KW
WEIGHT	9105 KG



EXCAVATOR 9 TONNE EXCAVATOR



This mid-range excavator allows you to put power and precision where you need it. The spacious cab has excellent visibility. This digger is available with zero tail swing so it can work in narrow areas, reducing the likelihood of accidents.



MAX DIGGING DEPTH	4170 MM
WIDTH	2300 MM
HEIGHT	2680 MM
FUEL TANK CAP	110 LTRS
ENGINE SIZE	43.8 KW
WEIGHT	9000 KG



EXCAVATOR 14 TONNE EXCAVATOR



These machines allow you to tackle the larger jobs mini excavator cannot.



MAX DIGGING DEPTH	6040 MM
WIDTH	2690 MM
HEIGHT	2770 MM
FUEL TANK CAP	223 LTRS
ENGINE SIZE	74 KW
WEIGHT	14500 KG



EXCAVATOR
16 TONNE WHEELED EXCAVATOR



Mounted on rubber tyres, this excavator is ideal for tackling utility work and street maintenance whilst preventing damage to ground surfaces.

SEATBELT BEACON SECURITY FOB*

MAX DIGGING DEPTH	4490-5052 MM
WIDTH	2500 MM
HEIGHT	3242 MM
FUEL TANK CAP	280 LTRS
ENGINE SIZE	102.2 KW
WEIGHT	16000 KG



BUCKETS
CONCRETE BUCKET



For 14 tonne excavators, this bucket is used for transportation and pouring of concrete and other materials when attached to an excavator.



EXCAVATOR
21 TONNE EXCAVATOR



One of the largest excavators in our hire fleet suitable for large construction and demolition work.

SEATBELT BEACON SECURITY FOB*

MAX DIGGING DEPTH	6670 MM
WIDTH	2990 MM
HEIGHT	2950 MM
FUEL TANK CAP	400 LTRS
ENGINE SIZE	128.4 KW
WEIGHT	22170 KG



BUCKETS
RIDDLE BUCKET



This bucket is an indispensable tool for any job involving sorting or riddling out stone from soil.



BUCKETS
RIPPER TOOTH



The ripper tooth attachment makes light work of hard or rocky ground, helping to reduce wear and stress on both the bucket and the machine.



EXCAVATOR
23 TONNE EXCAVATOR



The largest excavators in our hire fleet suitable for large construction and demolition work.

SEATBELT BEACON SECURITY FOB*

MAX DIGGING DEPTH	6080 MM
WIDTH	2990 MM
HEIGHT	2980 MM
FUEL TANK CAP	480 LTRS
ENGINE SIZE	125 KW
WEIGHT	2217 KG



FORKS
PALLET FORKS TO SUIT 8, 14 AND 20 TONNE EXCAVATORS



A great attachment for our mid-range to larger machines, it allows you to do almost everything a forklift can do without the extra cost of hiring another machine.



EXCAVATOR ADDONS
CAB GUARD

If you are having problems with vandals on site, these window guards can keep diggers safe overnight and at weekends.



EXCAVATOR ADDONS
RUBBER PADS

Protect asphalt or concrete roads, driveways, curbs, sidewalks, floors and grassy areas from steel tracked machinery. Fitted to excavators between 13 - 24 tonne.



09 |

DUMPERS

[VISIT WEBPAGE](#)





TRACKED DUMPER
1 TONNE TRACKED BARROW



These narrow access barrows will fit through gates and doorways that the larger dumpers will not. Very suitable for gardens with limited access.

- HARD HAT REQUIRED
- SECURITY FOB*

PAYLOAD	1000 KG
WIDTH	750 MM
HEIGHT	1325 MM
ENGINE SIZE	10.4 KW
FUEL TANK CAP	5.5 LTRS
WEIGHT	670 KG
TRANSMISSION	HYDRAULIC



TRACKED DUMPER
3 TONNE TRACKED DUMPER



These dumpers are ideal for working in boggy and sensitive ground conditions. They can travel on steep inclines where a normal rubber tyre dumper cannot.

- HARD HAT REQUIRED
- SEATBELT BEACON
- SECURITY FOB*

PAYLOAD	2500 KG
WIDTH	1550 MM
HEIGHT	2310 MM
ENGINE SIZE	34.3 KW
FUEL TANK CAP	58 LTRS
WEIGHT	2575 KG
TRANSMISSION	HYDROSTATIC



DUMPER
1 TONNE HI TIP DUMPER



For those awkward sites with restricted access, this small dumper can fit anywhere.

- HARD HAT REQUIRED
- SEATBELT BEACON
- SECURITY FOB*

PAYLOAD	1000 KG
WIDTH	1115 MM
HEIGHT	2860 MM
ENGINE SIZE	15.9 KW
FUEL TANK CAP	21 LTRS
WEIGHT	1215 KG
TRANSMISSION	HYDROSTATIC



DUMPER
3 TONNE SWIVEL DUMPER



These mighty dumpers are hard to beat around the site. Perfect for heavy loads of top soil and earth.

- HARD HAT REQUIRED
- SEATBELT BEACON
- SECURITY FOB*

PAYLOAD	3000 KG
WIDTH	1650 MM
HEIGHT	3092 MM
ENGINE SIZE	24.8 KW
FUEL TANK CAP	24.5 LTRS
WEIGHT	2190 KG
TRANSMISSION	HYDROSTATIC



DUMPER
3 TONNE FORWARD TIP DUMPER



The workhorse of the construction site, this powerful 4x4 dumper is perfect for shifting mortar, bricks, concrete and light loads of top soil.

- HARD HAT REQUIRED
- SEATBELT BEACON
- SECURITY FOB*

PAYLOAD	3000 KG
WIDTH	1650 MM
HEIGHT	3092 MM
ENGINE SIZE	24.8 KW
FUEL TANK CAP	24.5 LTRS
WEIGHT	2060 KG
TRANSMISSION	HYDROSTATIC



DUMPER
6 TONNE FORWARD TIP DUMPER



The workhorse of the construction site, this powerful 4x4 dumper is perfect for shifting mortar, bricks, concrete and top soil. Its larger capacity increases productivity on site.

- HARD HAT REQUIRED
- SEATBELT BEACON
- SECURITY FOB*

PAYLOAD	6000 KG
WIDTH	2300 MM
HEIGHT	2906 MM
ENGINE SIZE	55 KW
FUEL TANK CAP	65 LTRS
WEIGHT	4195 KG
TRANSMISSION	POWERSHUTTLE



DUMPER 6 TONNE SWIVEL DUMPER



When materials need to be dumped in tight spots or when you can't close off a road but need to fill a trench, these swivel skip machines are perfect. Allows discharge at 90 degrees to direction of travel.

HARD HAT REQUIRED SEATBELT BEACON SECURITY FOB*

PAYLOAD	6000 KG
WIDTH	2207 MM
HEIGHT	2906 MM
ENGINE SIZE	55 KW
FUEL TANK CAP	65 LTRS
WEIGHT	4335 KG
TRANSMISSION	POWERSHUTTLE



DUMPER 9 TONNE FORWARD TIP DUMPER



With a huge 9 tonne of carry capacity, this dumper gives extra added value on sites small and large.

HARD HAT REQUIRED SEATBELT BEACON SECURITY FOB*

PAYLOAD	9000 KG
WIDTH	2500 MM
HEIGHT	3389 MM
ENGINE SIZE	55 KW
FUEL TANK CAP	65 LTRS
WEIGHT	4915 KG
TRANSMISSION	POWERSHUTTLE



DUMPER 6 TONNE SWIVEL CABBED DUMPER



The cabbed dumper range gives all the benefits of material movement whilst providing a safe and modern environment for the operator.

SEATBELT BEACON SECURITY FOB*

PAYLOAD	6000 KG
WIDTH	2230 MM
HEIGHT	2993 MM
ENGINE SIZE	55 KW
FUEL TANK CAP	83 LTRS
WEIGHT	4938 KG
TRANSMISSION	HYDROSTATIC



DUMPER 9 TONNE SWIVEL DUMPER



When materials need to be dumped in tight spots or when you can't close off a road but need to fill a trench, these swivel skip machines are perfect. Allows discharge at 90 degrees to direction of travel. Its larger capacity increases productivity on site.

HARD HAT REQUIRED SEATBELT BEACON SECURITY FOB*

PAYLOAD	9000 KG
WIDTH	2380 MM
HEIGHT	3389 MM
ENGINE SIZE	55 KW
FUEL TANK CAP	65 LTRS
WEIGHT	5095 KG
TRANSMISSION	POWERSHUTTLE



DUMPER 9 TONNE CABBED DUMPER



The additional cab combined with a large carrying capacity make it ideal for all-year-round on medium to large construction sites.

SEATBELT BEACON SECURITY FOB*

PAYLOAD	9000 KG
WIDTH	2463 MM
HEIGHT	3053 MM
ENGINE SIZE	55 KW
FUEL TANK CAP	83 LTRS
WEIGHT	5514 KG
TRANSMISSION	HYDROSTATIC

* Security fob available on request - subject to availability

DUAL VIEW DUMPERS

AFTER 180° ROTATION
The skip and therefore the working area are still ideally in view in this seat position

SAFETY REDEFINED

Always perfect line-of-sight in the main driving direction - as with a truck



EASY AND INTUITIVE OPERATION
Thanks to the fully hydrostatic drive

INCREASED OPERATING COMFORT DUE TO AN ERGONOMIC SWIVEL CONSOLE

SCREEN FOR STANDARD REAR VIEW CAMERA

with lockable anti-vandalism protection; screen and camera meet IP69 requirements

STEERING COLUMN WITH TILT ADJUSTMENT

facilitates safe ascent and descent

ADDITIONAL STORAGE POSSIBILITY



MULTIFUNCTIONAL DISPLAY
for machine functions

JOYSTICK HANDLE
with travel direction change-over and skip actuation

EASY 180° ROTATION
no time-consuming turning maneuvers

ROTATING ASSEMBLY MOUNTED ON BEARINGS
for quick change of the sitting position



DUAL VIEW DUMPER

6 TONNE SWIVEL CABBED DUAL VIEW DUMPER



The cabbed dumper range gives all the benefits of material movement, whilst providing a safe and modern environment for the operator. These new dual view cabbed dumpers set new standards of manoeuvrability and an unobstructed view in any situation.



PAYLOAD	6000 KG
WIDTH	2250 MM
HEIGHT	3078 MM
ENGINE SIZE	55 KW
FUEL TANK CAP	73 LTRS
WEIGHT	4640 KG
TRANSMISSION	HYDROSTATIC

DUAL VIEW DUMPER

9 AND 10 TONNE DUAL VIEW DUMPER



The largest capacity dumpers in the Dual View range, the 9 and 10 tonne dumpers offer exceptional operator and construction site safety, by allowing the operator to conveniently change the control panel and seat by a 180-degree rotation.



PAYLOAD	9000 KG	10000 KG
WIDTH	2420 MM	2504 MM
HEIGHT	3382 MM	3382 MM
ENGINE SIZE	55.4 KW	55.4 KW
FUEL TANK CAP	80 LTRS	80 LTRS
WEIGHT	4870 KG	5041 KG
TRANSMISSION	HYDROSTATIC	HYDROSTATIC



* Security fob available on request - subject to availability

10 | DUMP TRUCKS

VISIT WEBPAGE



DUMP TRUCK 10 TONNE DUMP TRUCK



These straight tip cabbed dump trucks have all the benefits of their smaller cabbed relations, but with larger carrying capacity for the bigger construction sites.

SEATBELT BEACON SECURITY FOB*

PAYLOAD	10000 KG
WIDTH	2490 MM
HEIGHT	2750 MM
ENGINE SIZE	108 KW
FUEL TANK CAP	140 LTRS
WEIGHT	7970 KG
TRANSMISSION	AUTOMATIC ZF WG 115 ERGO POWER



DUMPER 12 TONNE SWIVEL DUMPER



The capability to move both seat and skip by 180° allows for an optimal viewing position when tipping into a trench, alongside 4x4 all-wheel drive and crab steering options to get into confined spaces.

SEATBELT BEACON SECURITY FOB*

PAYLOAD	12000 KG
WIDTH	2360 MM
HEIGHT	3130 MM
ENGINE SIZE	90 KW
FUEL TANK CAP	175 LTRS
WEIGHT	7960 KG
TRANSMISSION	HYDROSTATIC AUTOMOTIVE



11 | COMPACTION

VISIT WEBPAGE



ROLLER

80 TWIN DRUM ROLLER



These narrow ride-on rollers provide excellent compaction on paths and driveways.

HARD HAT REQUIRED SEATBELT BEACON SECURITY FOB*

COMPACTION FORCE	25/16 KN
DRUM WIDTH	800 MM
FUEL TANK CAP	33 LTRS
ENGINE SIZE	14.8 KW
WEIGHT	1840 KG



ROLLER

120 TWIN DRUM ROLLER



Ideal for compaction of large yards, 4" stones and preparation of roads and courtyards by contractors.

HARD HAT REQUIRED SEATBELT BEACON SECURITY FOB*

COMPACTION FORCE	52/32 KN
DRUM WIDTH	1200 MM
FUEL TANK CAP	42 LTRS
ENGINE SIZE	22.9 KW
WEIGHT	3410 KG



ROLLER

140 TWIN DRUM ROLLER



The largest tandem roller in our fleet provides excellent compaction on all civils and highway projects. Request a compaction chart from your local depot.

HARD HAT REQUIRED SEATBELT BEACON SECURITY FOB*

COMPACTION FORCE	64/39 KN
DRUM WIDTH	1380 MM
FUEL TANK CAP	73 LTRS
ENGINE SIZE	34.6 KW
WEIGHT	5300 KG



ROLLER

13 TONNE SELF PROPELLED ROLLER



For larger sites and preparatory soil compaction, this roller will not be beaten. Modern compaction technology combined with brute force gives the desired results in the optimum amount of passes.

- SEATBELT BEACON
- SECURITY FOB*

COMPACTION FORCE	285/196 KN
DRUM WIDTH	2130 MM
FUEL TANK CAP	250 LTRS
ENGINE SIZE	95 KW
WEIGHT	14800 KG



ROLLER

13 TONNE SELF PROPELLED PADFOOT ROLLER



For thicker lifts and more cohesive materials, a padfoot drum allows increased compaction. The drum design allows the operator to drive out water and air whilst giving the desired compaction.

- SEATBELT BEACON
- SECURITY FOB*

COMPACTION FORCE	285/196 KN
DRUM WIDTH	2130 MM
FUEL TANK CAP	250 LTRS
ENGINE SIZE	95 KW
WEIGHT	14800 KG



TRENCH ROLLER

TRENCH ROLLER



For those applications that are difficult for the operator to reach, a trench roller with its remote control capabilities ensures the correct level of compaction. These effective and durable machines are available in two drum widths.

- HARD HAT REQUIRED
- SECURITY FOB*

COMPACTION FORCE	72/36 KN
DRUM WIDTH	610/850 MM
FUEL TANK CAP	24 LTRS
ENGINE SIZE	14.5 KW
WEIGHT	1585 KG

12 |

TELEHANDLERS

[VISIT WEBPAGE](#)



TELEHANDLER

4 METRE TELEHANDLER

These compact telehandlers are perfect for lifting in confined spaces, with their narrow width, small inside radius and lift height of over 4 metres.

PAYLOAD	1200 KG
MAX LIFTING HEIGHT	4.5 M
WIDTH	1560 MM
HEIGHT	1940 MM
FUEL TANK CAP	25 LTRS
WEIGHT	2700 KG



- SEATBELT BEACON
- SECURITY FOB*

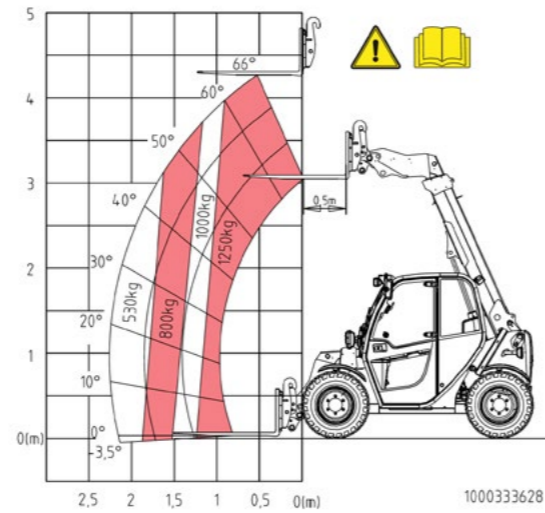

TELEHANDLER

6 METRE TELEHANDLER

These small-sized telescopic telehandlers are perfect when working in restricted areas.

PAYLOAD	2700 KG
MAX LIFTING HEIGHT	6.1 M
WIDTH	1840 MM
HEIGHT	1920 MM
FUEL TANK CAP	70 LTRS
WEIGHT	4900 KG



- SEATBELT BEACON
- SECURITY FOB*

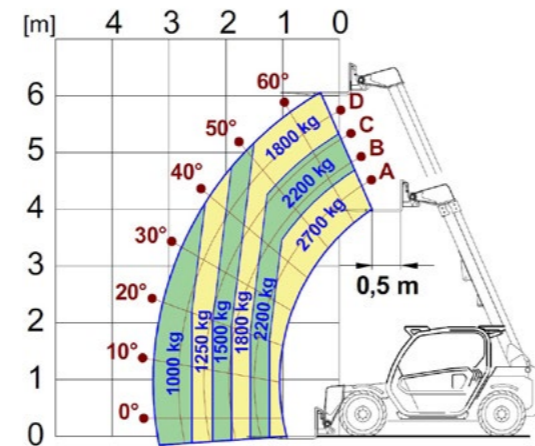

TELEHANDLER

9 METRE TELEHANDLER

These mid-range telehandlers offer compact dimensions with excellent manoeuvrability and performance, giving a load placement height of 8.6 meters.

PAYLOAD	3000 KG
MAX LIFTING HEIGHT	8.6 M
WIDTH	2100 MM
HEIGHT	2120 MM
FUEL TANK CAP	80 LTRS
WEIGHT	7100 KG



- SEATBELT BEACON
- SECURITY FOB*

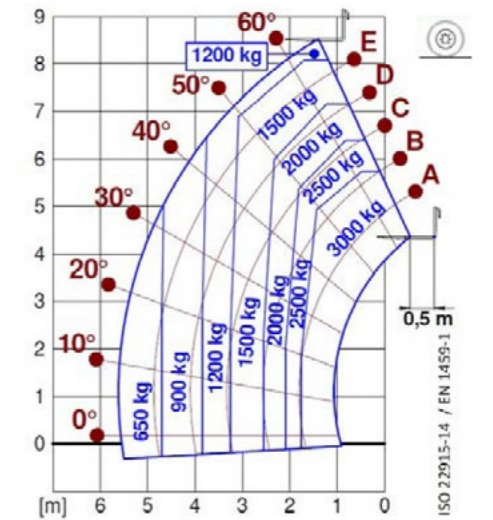

TELEHANDLER

10 METRE TELEHANDLER

These telescopic handlers are perfect for heavy duty lifting around the building site. Large loads can be placed safely to a height of up to 9.5 metres.

PAYLOAD	3000 KG
MAX LIFTING HEIGHT	9.6 M
WIDTH	2100 MM
HEIGHT	2120 MM
FUEL TANK CAP	80 LTRS
WEIGHT	7100 KG



- SEATBELT BEACON
- SECURITY FOB*

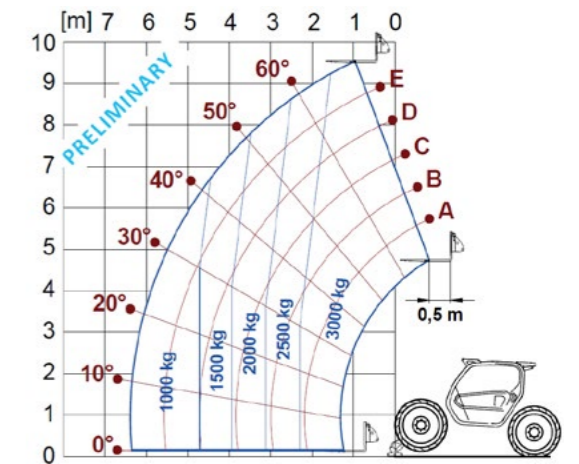

TELEHANDLER 12.5 METRE TELEHANDLER

These telescopic handlers are perfect for heavy duty lifting around the building site. Large loads can be placed safely to a height of up to 12 metres.

PAYLOAD	3500 KG
MAX LIFTING HEIGHT	12.27 M
WIDTH	2350 MM
HEIGHT	2500 MM
FUEL TANK CAP	125 LTRS
WEIGHT	10066 KG



- SEATBELT BEACON
- SECURITY FOB*

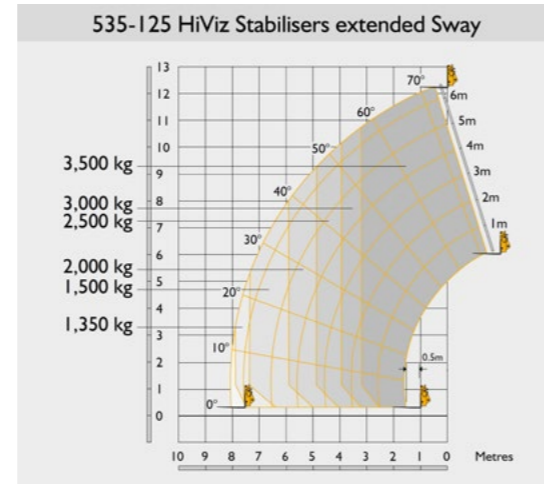

TELEHANDLER 18 METRE TELEHANDLER

The largest of our range of telehandlers, this versatile machine will lift 4 tonne at close range, with an overall reach of 18 metres.

PAYLOAD	4000 KG
MAX LIFTING HEIGHT	17.55 M
WIDTH WITH STABILISERS RAISED	2.42 MM
HEIGHT	2.5 MM
FUEL TANK CAP	140 LTRS
WEIGHT	11700 KG



- SEATBELT BEACON
- SECURITY FOB*

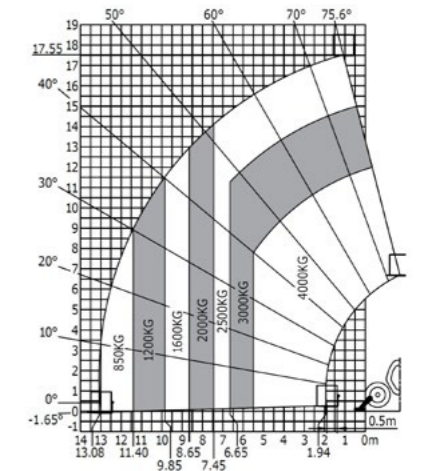

TELEHANDLER 14 METRE TELEHANDLER

These telescopic handlers are perfect for heavy duty lifting around the building site. Large loads can be placed safely to a height of up to 13.5 metres.

PAYLOAD	4000 KG
MAX LIFTING HEIGHT	13.78 M
WIDTH	2350 MM
HEIGHT	2590 MM
FUEL TANK CAP	146 LTRS
WEIGHT	11090 KG



- SEATBELT BEACON
- SECURITY FOB*

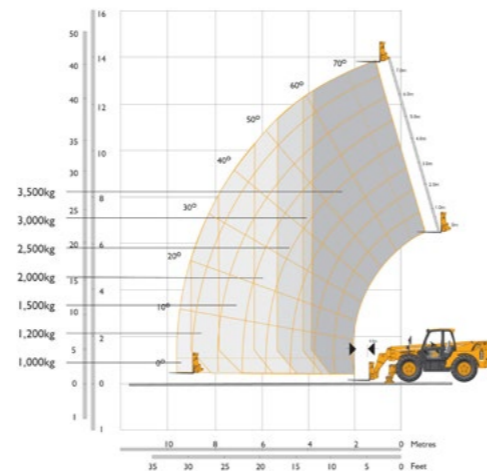

CRANE HOOK 4 TONNE FORK MOUNTED CRANE HOOK

These can be attached to our telehandlers for lifting equipment with chains. They have a 360 degree revolving hook for easier lifting.



EXTENSION FORKS FORK EXTENSIONS

These extensions fit over the existing forks to offer an extended reach. The lifting capacity of the forklift will be derated using these extensions.





BUCKET ATTACHMENT
MATERIAL REHANDLING BUCKET



This bucket is designed to handle a multitude of different materials, offering a quick and easy method of transporting large bulk materials.



SWEEPER ATTACHMENT
MULTI SWEEP 500



The ideal sweeper attachment to fit our telehandlers.

SWEEPING WIDTH	2000 MM
DEBRIS CONTAINER CAP	425 LTRS
WATER TANK CAP	200 LTRS
WEIGHT	870 KG



SKIP ATTACHMENT
TIPPING SKIP



This tipping skip offers a faster, easier, and safer method of transporting waste material for use on our telehandlers.

CAPACITY	1.2 M ³
----------	--------------------

13 |

BOWSERS

[VISIT WEBPAGE](#)



BOWSERS

Our double bunded fuel bowsers help minimise pollution risk from any potential fuel spills. These come in both static and mobile storage options in various sizes making it ideal to easily refuel on site.

CP Hire also provide a number of towable water and pressure washer bowsers within our fleet.



FUEL BOWSER 950 LTR SITE TOW FUEL BOWSER



These bowsers are fully bunded to protect against fuel spillage, with a site tow chassis.

EYE PROTECTION GLOVES REQUIRED

CAPACITY	985 LTRS
WIDTH	1130 MM
HEIGHT	1245 MM
LENGTH	1680 MM
WEIGHT (EMPTY/FULL)	70 / 1406 KG



FUEL BOWSER 1943 LTR ROAD TOW FUEL BOWSER



These larger capacity fuel bowsers are fully bunded to protect against fuel spillage and come complete with a hand discharge pump. Perfect for towing around site with the site tow chassis option.

EYE PROTECTION GLOVES REQUIRED

CAPACITY	1940 LTRS
WIDTH	1416 MM
HEIGHT	1276 MM
LENGTH	2270 MM
WEIGHT (EMPTY/FULL)	705 / 2548 KG



FUEL BOWSER 1000 LTR STATIC FUEL BOWSER



These static fuel bowsers are fully bunded to protect against fuel spillage and come complete with a hand discharge pump. Ideal for bulk storage and distribution of fuel on-site.

EYE PROTECTION GLOVES REQUIRED

CAPACITY	950 LTRS
WIDTH	1143 MM
HEIGHT	1320 MM
LENGTH	1143 MM
WEIGHT (EMPTY/FULL)	513 / 1451 KG



FUEL BOWSER 2000 LTR STATIC FUEL BOWSER



This larger capacity static fuel bower is fully bunded to protect against fuel spillage and come complete with a hand discharge pump. Ideal for bulk storage and distribution of fuel on-site.

EYE PROTECTION GLOVES REQUIRED

CAPACITY	1987 LTRS
WIDTH	1143 MM
HEIGHT	1320 MM
LENGTH	2286 MM
WEIGHT (EMPTY/FULL)	830 / 2951 KG



WATER BOWSER

1100 LTR SITE TOW WATER BOWSER



These mobile site tow bowzers provide bulk water anywhere on site where no main supply is available.

CAPACITY	1100 LTRS
WIDTH	1560 MM
HEIGHT	1350 MM
LENGTH	3500 MM
WEIGHT (EMPTY/FULL)	350 / 1500 KG



BOWSER

1100 LTR ROAD TOW PRESSURE WASHER BOWSER



A heavy duty, diesel powered, pressure washer suitable for towing on public roads.

EYE PROTECTION GLOVES REQUIRED

CAPACITY	1100 LTRS
WIDTH	1560 MM
HEIGHT	1350 MM
LENGTH	3500 MM
WEIGHT (EMPTY/FULL)	350 / 1500 KG



14 |

TRAILERS AND WELFARE UNITS

[VISIT WEBPAGE](#)





WELFARE UNIT
MOBILE WELFARE UNIT - GROUNDHOG



These units are suitable for accommodating up to 6 people to provide a pleasant, and safe working environment.

MAX NUMBER OF PERSONNEL	6
WIDTH	2300 MM
LENGTH	3600 MM
WEIGHT	1800 KG
GENERATOR	6 KVA



TRAILER
1.5 TONNE PLANT TRAILER



Hire a modern trailer to transport your smaller construction equipment with ease, giving you the flexibility of moving from site to site.

PAYLOAD	2152 KG
WIDTH	1800 MM
HEIGHT	1700 MM
LENGTH	4670 MM
WEIGHT	548 KG
GROSS VEHICLE WEIGHT	2700 KG



TRAILER
3 TONNE PLANT TRAILER



Hire a modern trailer to transport your smaller construction equipment with ease, giving you the flexibility of moving from site to site.

PAYLOAD	2740 KG
WIDTH	1800 MM
BED HEIGHT	456 MM
LENGTH	3050 MM
WEIGHT	760 KG
GROSS VEHICLE WEIGHT	3500 KG



Each unit boasts a canteen complete with cooking and eating facilities. A self-contained toilet with hand washing facilities, and a separate drying room. They are powered by a built-in 6Kva generator, and supplied with a weekly cleaning service.

15 |

PORTABLE COMPRESSED AIR

VISIT WEBPAGE



PORTABLE COMPRESSED AIR HEAVY AIR BREAKER



The ergonomic anti-vibration handles increase the operator's comfort whilst minimising vibration levels. Ideal for breaking up roads, pavements, paths and concrete slabs or demolition work.

HARD HAT REQUIRED EYE PROTECTION GLOVES REQUIRED

AIR USAGE	44 CFM
WEIGHT	25 KG
LENGTH	735 MM
BORE	Ø : 55 MM
BPM	1380
SOUND LEVEL	94.4 dB



PORTABLE COMPRESSED AIR MEDIUM AIR BREAKER



This medium SK10 air breaker can be used for concrete or stone and is also ideal for light demolition work.

HARD HAT REQUIRED EYE PROTECTION GLOVES REQUIRED

AIR USAGE	34 CFM
WEIGHT	11.8 KG
LENGTH	520 MM
BORE	Ø : 38 MM
BPM	1860
SOUND LEVEL	94.7 dB



PORTABLE COMPRESSED AIR SMALL AIR CHIPPING BREAKER



The small SK5 air chipping Hammer is lightweight and powerful for size. Perfect for tight angles and working at height.

HARD HAT REQUIRED EYE PROTECTION GLOVES REQUIRED

AIR USAGE	17 CFM
WEIGHT	5.3 KG
LENGTH	387 MM
BORE	Ø : 28 MM
BPM	3940
SOUND LEVEL	95.5 dB





PORTABLE COMPRESSED AIR 160 CFM COMPRESSOR



These compact towable machines provide portable compressed air wherever required, whether on site or at the roadside. Powerful enough to drive two medium air breakers for your smaller concrete breaking requirements.



HARD HAT REQUIRED



EYE PROTECTION



GLOVES REQUIRED

AIR DELIVERY	160 CFM
WIDTH	1350 MM
HEIGHT	1400 MM
LENGTH	2290 MM
FUEL TANK CAP	60 LTR
WEIGHT	750 KG
ENGINE SIZE	33 KW
PRESSURE	7 BAR / 101.5 PSI



All our compressors come with mandatory whip checks and air hoses alongside a selection of points and chisels.

HYDRAULIC BREAKERS

VISIT WEBPAGE

These powerful attachments are ideal for most types of demolition, landscaping and roadworks. We have breakers available for all excavator sizes from the smallest to the largest. They are perfect for rock breaking or breaking up large areas of reinforced concrete.

HYDRAULIC BREAKERS

1 TONNE HYDRAULIC BREAKER



WEIGHT	75 KG
REQUIRED OIL FLOW	12 - 22 IPM
OPERATING PRESSURE BAR	100 - 130
TOOL DIAMETER	42 MM

HYDRAULIC BREAKERS

1.5 TONNE HYDRAULIC BREAKER



WEIGHT	123 KG
REQUIRED OIL FLOW	15 -25 IPM
OPERATING PRESSURE BAR	100 - 130
TOOL DIAMETER	45 MM

HYDRAULIC BREAKERS

3 TONNE HYDRAULIC BREAKER



WEIGHT	149 KG
REQUIRED OIL FLOW	20 - 35 IPM
OPERATING PRESSURE BAR	100 - 130
TOOL DIAMETER	50 MM

HYDRAULIC BREAKERS

5-8 TONNE HYDRAULIC BREAKER



WEIGHT	284 KG
REQUIRED OIL FLOW	35 - 65 IPM
OPERATING PRESSURE BAR	130 - 170
TOOL DIAMETER	68 MM

HYDRAULIC BREAKERS

14 TONNE HYDRAULIC BREAKER



WEIGHT	537 KG
REQUIRED OIL FLOW	60 - 110 IPM
OPERATING PRESSURE BAR	140 - 180
TOOL DIAMETER	93 MM

HYDRAULIC BREAKERS

20 TONNE HYDRAULIC BREAKER



WEIGHT	1564 KG
REQUIRED OIL FLOW	100 - 150 IPM
OPERATING PRESSURE BAR	160 - 180
TOOL DIAMETER	125 MM

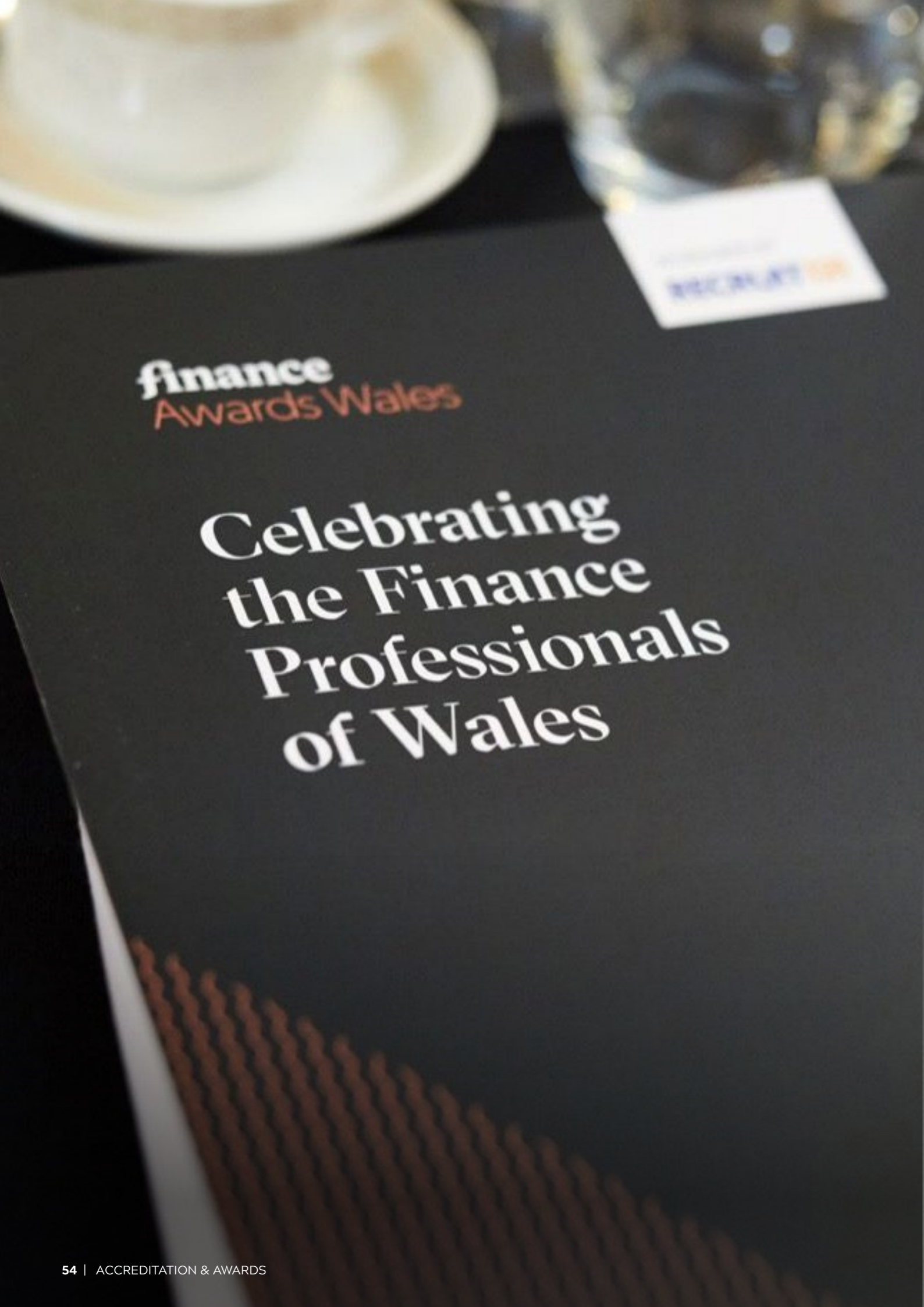

AWARD-WINNING AND ACCREDITATION CERTIFIED

Like many companies, we are always looking to continuously improve. Gaining accreditations for wider areas of the construction industry not only helps us on this journey but also gives our customers further support and knowledge on their worksite.

Safety is of paramount importance throughout our industry and this is clearly reflected with our FORS certified accreditation. All our depots are Safehire accredited through the Hire Association of Europe. Furthermore, we are also a Safe Contractor and Safety in Procurement qualified company.

All our depots go through a rigorous internal quarterly audit and we would

welcome the chance to talk you through our process.

Carrying RISQS accreditation enables us to support trackside for the huge volume of rail infrastructure works over the next decade and beyond.

Of course, being recognised by our peers and those outside our sector for our growth, stability and company culture is always rewarding. We have won a number of awards that recognises the huge team effort from all our staff which confirms we are the number one choice for many customers within the industry.



COMMUNITY LIVES AT THE HEART

Our values go further than Plant Hire with an avid passion for contributing to the local community. Throughout the company’s history, we’ve had the opportunity to partner with some of the most esteemed projects and charities in Great Britain, all in aid of a good cause.



LIGHTHOUSE CLUB

Within the field of construction, we work alongside the ‘Lighthouse Construction Industry Charity’ who offer “emotional, physical and financial support to construction workers and their families.”

Especially in the construction industry, the awareness of workers’ mental health and wellbeing has often been overlooked in the past. However, with the help of the Lighthouse Club, we believe the wellbeing of workers is priority number one which is why we run regular health and safety events through our ‘CP Safe’ initiative.



DUKE OF EDINBURGH’S AWARDS SCHEME

Supporting the next generation is imperative. As a company, we appreciate the impression schemes like the Duke of Edinburgh’s Awards can make on a young person.

That’s why CP Hire offers commercial support for such projects that give young people the platform to express themselves and help boost self-confidence.



CRAWSHAYS WELSH RFC

Crawshays Welsh RFC is one of the world’s most iconic invitational rugby union sides having been in existence for nearly 100 years. Not only do they field a first-class side to play teams from all over the UK and beyond, but they have a strong belief in youth rugby. Believing that all promising players have the chance to shine on a wider stage and develop skills that hitherto may go unnoticed.

CP Hire’s commercial partnership with Crawshays enables youth players not only to train, but to travel far and wide as well. Some of these players have even gone on to represent their country.

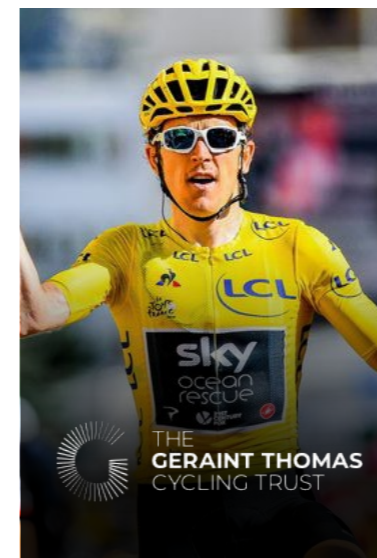

GERAINT THOMAS CYCLING TRUST

Launched in 2021, the ‘Geraint Thomas Cycling Trust’ believes social and/or economic background should not be a barrier to getting on a bike. All children and young adults should be encouraged and given the opportunity to taste cycling and experience the mental and physical benefits that it can bring.

With our contributions and partnership, the GTCT is helping to break down these hurdles and build independence for budding cyclists by offering them the opportunity to exercise together, and form lasting relationships.

19 |

OPERATED PLANT HIRE

Covering the entire CP Hire network, we have an experienced team of fully qualified plant operators coordinated through our specialist and designated Operated Plant department.

All of our operators are CPCS accredited and have extensive knowledge of operated plant within the fleet. We supply operators to the construction, engineering and rail industry for both on and off-track projects. These experienced handpicked operators carry PTS/Sentinel cards and are fully conversant with all rail requirements and legislation.

If you need a contracted driver for the duration of your site or cover for a few weeks, hiring our plant together with an operator can be an efficient solution.

Email: operated@cphire.com

Phone: 0845 505 70 70 (Option 2 - Option 4)





20 |

OPENING AN ACCOUNT

We welcome your business with open arms. Account forms are available from your nearest depot, your local Area Sales Manager or to [download from our website](#).*

Alongside your form, we also ask you to provide your hired-in plant insurance as well as a list of contacts within your business to ensure we can provide the best service possible. Upon submission, review of your account application can take up to 24 hours. After a successful application, you will be provided with an official letter of acceptance which includes your credit limit.

From there onwards, within your assigned credit limit, you can raise hire orders by contacting your local Area Sales Manager or Hire Desk Controller who will be happy to take your enquiry.

APPLY NOW

*The security of hired plant is the customer's responsibility, the full value of all hired plant must be adequately covered by insurance. Any damage caused to hired or Operated plant is the customer's responsibility and will be charged for. CP Hire GB Ltd is a member of the Hire Association Europe (HAE) and as such abides by their terms and conditions. By opening an account with us you are also agreeing to these Terms & Conditions. These will be made available upon request or when opening an account.

FOR ENQUIRIES PLEASE CALL

0845 505 70 70

HEAD OFFICE

Hours: 7:30am - 5pm, Mon - Fri

Address: 2 Village Way, Greenmeadow Springs, Cardiff CF15 7NE

Email: info@cphire.com | service@cphire.com

01 |

CARDIFF

Address: Nordic House,
Longships Road,
Cardiff Docks, Cardiff,
CF10 4RP

Email: cardiff@cphire.com

02 |

BRISTOL

Address: B, Port Edward Centre,
St Andrews Road,
Avonmouth, Bristol,
BS11 9HS

Email: bristol@cphire.com

03 |

SWANSEA

Address: 138 Heol-Y-Gors,
Cwmbwrla,
Swansea,
SA5 8LT

Email: swansea@cphire.com

04 |

OPERATED PLANT

Address: Nordic House,
Longships Road
Cardiff Docks, Cardiff,
CF10 4RP

Email: operated@cphire.com

05 |

BIRMINGHAM

Address: 15 Chancel Way,
Halesowen,
Birmingham,
B62 8SE

Email: birmingham@cphire.com

06 |

NEWBURY

Address: The Gate House,
Ampere Road,
Newbury,
RG14 2AE

Email: newbury@cphire.com

CPHire 

@cphiregb

